



163rd NYYC ANNUAL REGATTA

Presented by ROLEX

June 9-11, 2017
Newport, Rhode Island

SAILING INSTRUCTIONS

1 RULES

- 1.1 The regatta will be governed by the rules as defined in the *Racing Rules of Sailing* (RRS). RRS Addendum D, Team Racing Rules, will not apply for the Rolex Cup or Great Corinthian Trophy team events.
- 1.2 **Safety Equipment Requirements:** All yachts shall comply with the US Nearshore section of the NOR Addendum 1 – US Safety Equipment Requirements (USSER) and shall comply with their class rules, where applicable.
 - USSER 2.4.2 through 2.4.8 regarding Hull and Structure: Lifelines shall apply, except that yachts not normally rigged with lifelines are exempt for these requirements and shall wear approved PFDs at all times while racing. This requirement does not apply to Classics, 6 Metres or 12 Metres, although they are strongly encouraged to wear PFDs.
 - In the event of a conflict between these Requirements and applicable class rules, the class rules shall apply.
- 1.3 The US SAILING Prescriptions to the RRS posted as NOR Addendum 2 on the Annual Regatta website shall apply.
- 1.4 The 2017 CRF MKII formulae shall apply to all yachts sailing in the Classics or Spirit of Tradition classes.
- 1.5 The 2017 IRC Rules and Regulations paragraphs A, B and C shall apply to yachts racing under IRC. For the purposes of IRC Rules 21.1.5 (d) and (e), the Around-the-Island Race on Friday is considered to be a separate regatta.
- 1.6 The 2017 PHRF-NB Regulations shall apply to yachts racing under PHRF. There are no crew weight limits.
- 1.7 The 2017 ORC Rating Systems shall apply to yachts racing under ORC.
- 1.8 The current class rules shall apply to all yachts racing as a one-design class, except as noted in these sailing instructions.
- 1.9 12 Metre Class only: 12 Metre Class only: Man Overboard - In the event that a crew member has been lost overboard and detached from the yacht, then that yacht shall immediately:
 - a) sail clear and stand by to recover the crew member, and
 - b) notify the Race Committee on the fleet VHF channel that a crew member has been lost overboard.

It is expected that the closest vessel, including racing yachts or support boat shall immediately proceed to render aid. This provision DOES NOT modify Rule 1.1 in any way. The yacht whose crew member was lost overboard shall be scored equal to the number of starters without a hearing for that race. This changes RRS 63.1.

- 1.10 Swan 42 Class only:
- a) This is a Swan 42 Class Sanctioned Event.
 - b) For any Swan 42 electing to sail in the Swan 42 class in the Around-the-Island Race on Friday, June 12, the following will apply:
 - Yachts that comply with the Swan 42 Class One Design rules will be scored as a One Design Class.
 - Any Swan 42 that, when sailing in Class one design configuration, has a valid IRC certificate, will also be “double-scored” in the overall IRC fleet and is eligible for the overall IRC award.
 - A Swan 42 that has a valid IRC certificate, but does not comply with the Swan 42 Class One Design rules, shall be placed in an IRC class.
 - c) Swan 42 Class yachts that meet the eligibility and entry requirements for the Invitational Cup NYYC Team Selection Series or the Rolex NYYC Invitational Cup, but not those of Class Rule 7, may participate in the NYYC Annual Regatta. However, yachts that do not meet the eligibility requirements of Swan 42 Class Rule 7 shall not be eligible to win trophies described in NOR 14, nor be designated as the Swan 42 Class NYYC Annual Regatta Champion.
- 1.11 C&C 30 Class only: Class Rules Section J are invoked as follows:
- a) Rule J.3 shall apply at all times.
 - b) Rule J.4 shall only apply for the Around-the-Island Race on Friday, June 9.
 - c) For racing on Saturday and Sunday, June 10-11, the first sentence of RRS 29.1 is changed to read: When at a boat’s starting signal any part of her hull or crew is on the course side of the starting line or she must comply with RS 30.1, the race committee shall promptly display flag X with one sound. This changes RRS 29.1.
- 1.12 M32 Class only: Sailing Instructions Addendum D pertains to the Marstrom 32 class and describes changes to these sailing instructions.
- 1.13 **Liability Waiver:** No crew shall be aboard a yacht while racing unless he/she has executed the online Liability Waiver Form. The Liability Waiver Forms are available on the Annual Regatta website. Registration will not be complete without receipt of a complete Crew Waiver Form from each crew member.

2 ENTRIES

- 2.1 Eligible yachts shall enter by completing online registration with the Organizing Authority on the Annual Regatta website. Eligibility requirements for yachts and method of entry are detailed in the Notice of Race.
- 2.2 Team entries for the Rolex Cup and the Great Corinthian Trophy shall be entered on the separate entry forms posted on the Annual Regatta website. There is no entry fee for either team event.

3 COMMUNICATION WITH COMPETITORS

- 3.1 Notices, including race documents, results, and amendments, shall be posted on the Official Notice Board. Jury information, including protest time limits and hearing schedules, shall be posted on the Jury Notice Board. Both boards are located in the courtyard of the NYYC Sailing Center at Harbour Court. This information may also be posted on the Annual Regatta website.
- 3.2 Flag signals will be flown from the flagpole at Harbour Court.
- 3.3 Any change to the sailing instructions will be posted before 0900 on the day it will take effect, except that any change to the schedule of races will be posted by 2000 on the day before it will take effect. Flag “Lima” will be flown to signify such posting.
- 3.4 When pennant “AP” is displayed ashore, “one minute” is replaced with “not less than one hour” in race signal “AP”.
- 3.5 Signals designating the rendezvous locations will be displayed at 0900 each day from the flagpole at Harbour Court. The race committee will endeavor to announce the circle assignments, format and the rendezvous locations as described in SI 4 and SI 6 at that time over VHF Channel 72. The failure to make this announcement or for a yacht to hear this announcement will not be grounds for redress. This changes RRS 62.1(a).

- 3.6 VHF Channels - The race committee VHF channels for each circle are shown below:
- | | | | |
|------------------------|--------------|----------------|---|
| a) Friday, June 9 | Blue Circle | VHF Channel 72 | (All classes in Around-the-Island Race) |
| b) Sat/Sun, June 10-11 | Blue Circle | VHF Channel 72 | |
| | White Circle | VHF Channel 69 | |
| | Green Circle | VHF Channel 71 | |
| | Red Circle | VHF Channel 77 | |

4 CLASSES AND IDENTIFICATION

- 4.1 The Organizing Authority will divide yachts into classes.
- a) For the Around-the-Island Race on Friday, June 9, classes will be assigned a numeral designation and be designated the BLUE Circle.
- b) For racing on Saturday and Sunday, each class will be given a numeral designation and be assigned each day to one of four circles (Blue, White, Green, or Red). Note that a class may sail in different circles and be assigned different numeral designations on different days.
- 4.2 **Format** – For racing on Saturday and Sunday, the race committee will notify competitors (no later than 1900 on the day before they will take effect) of the circle assignments for each class and the intended type of racing for the following day:
- a) Navigator Races – SI Addendum A (using government marks and racing marks on Narragansett Bay and/or Rhode Island Sound)
- b) Drop Mark Races – SI Addendum B (using inflatable buoys on Rhode Island Sound and/or Narragansett Bay)
- 4.3 **Scratch Sheets** - There will be separate scratch sheets for the Around-the-Island Race on Friday and for the two-day Series on Saturday and Sunday. The scratch sheets designating class assignments will be distributed at registration, posted on the Official Notice Board and posted on the regatta website.
- 4.4 **Class Flags** – Each yacht shall display the numeral flag corresponding to her class designation, as shown on the scratch sheet, from her backstay approximately six feet above the deck and above the Rolex flag, from the warning signal of the first class on her circle until she is no longer racing. Yachts without a permanent backstay shall conspicuously display these flags in an alternate position in the aft part of the yacht.
- 4.5 **Bow Stickers and Flags** - Each yacht shall display the Rolex backstay flag and bow stickers provided at registration while racing. Wooden yachts and Classics are not required to apply the bow stickers.

5 SCHEDULE OF RACES

- 5.1 The Around-the-Island Race will be sailed on Friday, June 9. Course signals will be made on Friday, June 9, at 1100.
- 5.2 The TWO-DAY Series will be held on Saturday and Sunday, June 10-11. All races will count in the TWO-DAY Series. The course signals will be made at 1100 for all circles on Saturday, June 10 and Sunday, June 11.
- 5.3 No warning signal shall be made after 1500 on Sunday, June 11.

6 RENDEZVOUS LOCATIONS

Circle rendezvous locations are listed below and will be designated as described in SI 3.5. See SI Addendum C – NYYC Primary Race Areas.

Rhode Island Sound:

- Area “A” - in the vicinity of 160° for 1.2 NM from R “2” QR Whistle marking Brenton Point
- Area “B” - in the vicinity of 120° for 2.5 NM from R “2” QR Whistle marking Brenton Point
- Area “C” - in the vicinity of 225° for 2.0 NM from R “2” QR Whistle marking Brenton Point

Newport Harbor and near Newport Bridge:

- Area “K” - between Goat Island and Rose Island
- Area “M” - in the vicinity of R “12” west of Rose Island
- Area “O” - in the vicinity of Potter Cove (just north of west end of Newport Bridge)

North of Newport Bridge:

- Area “R” - in the vicinity of 200° for 0.5 NM from Halfway Rock
- Area “T” - in the vicinity of G “7” QG off Quonset Point

7 CHECK-IN AND RETIREMENT

- 7.1 Each yacht shall check-in at the registration desk at the NYYC Sailing Center at Harbour Court during the registration times so designated in the Notice of Race.
- 7.2 Around-the-Island Race: Prior to their course signal, each yacht shall check in with the race committee check-in boat displaying an L flag that will be anchored outside the starboard end of the starting box by sailing or motoring by the stern of the signal boat and announcing their sail number.
- 7.3 Saturday/Sunday Racing: Prior to their course signal each day, each yacht shall check in with the race committee signal boat by sailing or motoring by the stern of the signal boat and announcing their sail number.
- 7.4 The race committee may announce the lat/long positions of the signal boat and starting mark over the circle VHF channel. Failure to make such an announcement, nor the timing of any announcement, shall be grounds for redress. This changes RRS 62.1(a).
- 7.5 Yachts retiring are requested to inform the race committee on their circle VHF channel or by calling (401) 845-9633.

8 COURSES & MARKS

The courses and marks for each section of the Annual Regatta are described in the SI Appendices as shown:

Courses using Government Marks	SI Addendum A
Drop Mark Courses	SI Addendum B
M32 Courses	SI Addendum C

9 THE START

- 9.1 The intended order of starts for the Around-the-Island Race on Friday, June 9 will be included in the race committee's announcement on VHF Channel 72 at 0900. See SI Addendum A.
- 9.2 A yacht starting later than 10 minutes after her starting signal will be scored Did Not Start. This changes RRS A4.
- 9.3 The starting line will be between a staff displaying an orange flag on the race committee signal boat and the course side of the port-end starting mark.
- 9.4 Yachts shall keep clear of the race committee signal boat, the starting line, and the starting mark from the time of the course signals for the first race in the sequence until the warning signal for their class.
- 9.5 Around-the-Island Race: The race committee will delineate a STARTING BOX by placing two or more buoys to leeward of the starting line to form a starting box area between these buoys and the starting line. Yachts shall keep outside the starting box from the time of the course signals for a race until the warning signal for their class.
- 9.6 Sample sequence:
 - 1100 Course Signals
 - 1105 Warning for first class
 - 1106 Preparatory for first class
 - 1110 Start for first class, Warning for second class
 - 1111 Preparatory for second class
 - 1115 Start for second class, Warning for third class
 - 1116 Preparatory for third class
 - 1120 Start for third class, etc.

10 INDIVIDUAL RECALLS

The race committee will endeavor to hail each premature starter over their respective circle VHF channel. Failure to make such an announcement, nor the timing or order of any announcement, shall be grounds for redress. This changes RRS 62.1(a).

11 THE FINISH

The finishing line will be between a staff displaying a blue flag on the race committee signal boat and the course side of the finishing mark as described in the relevant SI Addendum.

12 GOVERNMENT BUOYS

Government buoys have no required side except when specified as marks of the course. Caution should be exercised for safe navigation.

13 PENALTY SYSTEM

- 13.1 For the Around-the-Island Race on Friday, June 9, the penalty described in SI 13.4 applies for all yachts. Class Rules do not apply.
- 13.2 In racing on Saturday and Sunday, if class rules specify a penalty, a yacht that may have broken a rule of Part 2 while racing may take a penalty at the time of the incident as provided in her class rules.
- 13.3 Swan 42 Class only: In racing on Saturday and Sunday, Class Rule 9.2 is in effect for Part 2 incidents between Swan 42s.
- 13.4 For all yachts where the class rules do not specify a penalty, RRS Appendix V shall apply.
- 13.5 The Protest Committee may impose suitable penalties, other than disqualification, for violations of the ISAF Offshore Special Regulations or other non-Part 2 rules. This changes RRS 64.1.
- 13.6 A yacht that has taken a penalty shall complete an online penalty acknowledgement form or a paper form available from the Jury Secretary and submit/file it with the Jury Secretary no later than the end of protest time.

14 TIME LIMIT

- 14.1 The time limit to sail the course and finish is as follows:
 - a) For courses designated in accordance with SI 3.4 or SI 3.5 – five hours.
 - b) For a course designated in accordance with SI A3.6 – three hours.
 - c) For courses designated in accordance with Addendum B – three hours.
- 14.2 Yachts failing to finish within the time limit will be scored Time Limit Expired (TLE) and scored points as described in SI 16.4. This changes RRS 35 and RRS A4.

15 PROTESTS AND REQUESTS FOR REDRESS

- 15.1 It is requested that yachts intending to protest report both their intention and the yacht being protested to the race committee on the circle VHF channel immediately after finishing or withdrawing from the race.
- 15.2 Protests or requests for redress shall be submitted to the Jury Secretary in the NYYC Sailing Center or on the online protest form as soon as possible, but not later than one hour after the race committee signal boat for that circle has docked. The time limit for filing a protest will be posted on the Official Notice Board.
- 15.3 Protest notices will be posted as soon as possible on the Jury Notice Board.
- 15.4 Protest hearings will take place at the NYYC Sailing Center as soon as possible after the notices are posted. The Jury will attempt to hear protests in the order of receipt. Representatives of yachts who are parties to a hearing shall remain on call in the vicinity of the protest rooms.
- 15.5 When a yacht has been involved in an incident that may be subject to protest, it is her responsibility to check the protest notices at the end of the protest filing time to see if she is cited in a protest. Failure of any yacht to appear when called for a hearing will be considered by the Jury as grounds for proceeding under RRS 63.3(b).
- 15.6 RRS 63.5 is changed by adding, “A protest involving contact may be heard by the Protest Committee even though the requirements of RRS 61.1(a) and 61.3 have not been fulfilled.”
- 15.7 Breaches of SIs 4.4, 4.5, 7, 9.5 and 9.6 will not be grounds for a protest by a yacht. This changes RRS 60.1(a).
- 15.8 The penalty for a breach of SI 9.5 or 9.6 shall be a minimum of two points. This changes RRS 64.1.

- 15.9 On the last scheduled day of racing only, a written request for reopening a hearing shall be delivered to the Jury Secretary:
- a) Within the protest time limit if the requesting party was informed of the Protest Committee's decision on the previous day; or
 - b) No later than 30 minutes after the requesting party was informed of the Protest Committee's decision on that day; or
 - c) If no races are held on the last scheduled day of racing, within one hour after racing has been abandoned.
- This changes RRS 66.
- 15.10 On the last scheduled day of racing, a request for redress based on a Protest Committee decision shall be delivered in writing no later than 30 minutes after the decision was posted. This changes RRS 62.2.

16 SCORING

- 16.1 The Around-the-Island Race on Friday, June 9, will be scored separately from racing on Saturday and Sunday.
- 16.2 In the Two-Day Series, a yacht's series score will be the total of her race scores. This changes RRS A2.
- 16.3 One race is required to be completed to constitute a series.
- 16.4 Yachts that have started and fail to finish within the time limit for any reason, shall, without a hearing, be scored Time Limited Expired (TLE) by the race committee and be assigned points equal to the number of yachts in her class that have sailed the course and finished within the time limit, plus two. This changes RRS A4.1, A4.2, and A5.
- 16.5 Teams competing for team trophies will be scored in accordance with the Notice of Race.
- 16.6 For scoring purposes, the distance used (as needed) will be that as calculated by the race committee.

17 PRIZES

Prizes will be awarded as described in the Notice of Race.

18 NOTES

- 18.1 Competitors are reminded that Narragansett Bay and its approaches are considered restricted channels for commercial traffic and other vessels restricted in their ability to maneuver. Competitors must comply with the government right-of-way rules when in proximity to commercial or privileged marine traffic.
- 18.2 In the event there is racing in Narragansett Bay, competitors should be aware of heightened security around the Navy base in Newport just to the north of the Newport Jamestown Bridge. The area may be defined by a series of white buoys marking the Newport Security Zone along the coast of the Naval Facilities from Coasters Harbor to the breakwater at the north end of Coddington Cove and the line defined by the buoys shall rank as an obstruction. Yachts shall not enter this area. A Navy patrol boat monitors the area and vessels navigating in the Exclusionary Zone may face action by Coast Guard and Naval authorities.
- 18.3 Additional restricted areas due to Navy activity, shipping or fishing operations may be described in an amendment to the sailing instructions.
- 18.4 All times herein are Eastern Daylight times. Bearings are in degrees magnetic and are approximate. Distances used herein are expressed in nautical miles (when not otherwise defined) and are approximate.
- 18.5 Newport Tides
- | Day | Date | High Tide | Height | Low Tide |
|----------|---------|-----------|---------|----------|
| Friday | June 9 | 0835 | 3.3 ft. | 1342 |
| Saturday | June 10 | 0912 | 3.3 ft. | 1424 |
| Sunday | June 11 | 0950 | 3.2 ft. | 1505 |
- 18.6 The Annual Regatta website can be found at <http://nyc.org/yachting/racing/163rd-annual-regatta>.

- 18.7 For further information please contact:

New York Yacht Club, Harbour Court
5 Halidon Avenue
Newport, RI 02840

Tel: 401-845-9633
Fax: 401-846-3303
Email: sailingoffice@nyc.org

SAILING INSTRUCTIONS

Addendum A – COURSES USING GOVERNMENT MARKS

A1 ORDER OF START

The intended order of start will be announced at course signals on the circle VHF Channel. Classes may not start in numerical order. The race committee may combine two or more classes into one start by displaying multiple class flags at the warning signal. The race committee will endeavor to announce the next class (es) to start on the circle VHF Channel.

A2 MARKS

A2.1 The starting mark will be a GREEN tetrahedron buoy.

A2.2 The finishing mark will be a PINK tetrahedron buoy.

A2.3 Special Marks “E” and “L”, if used, will be YELLOW tetrahedron buoys.

A2.4 If used, Special NYYC Temporary Inflatable Race Marks 16 and 17 as designated on the 2015-2017 South Bay Race Chart will be ORANGE tetrahedron buoys.

A3 COURSES

A3.1 All yachts shall pass through the **center span ONLY** for any course passing under the Jamestown Verrazano Bridge and/or the Newport Jamestown Bridge. For the purposes of RRS 32.2(c), the center span shall be considered a gate.

A3.2 Government marks shall have no required side except when designated as a rounding mark.

A3.3 The flag(s) designating the course to be sailed will be displayed at course signals. The race committee will endeavor to announce the designated courses over the circle VHF channel. Failure to make such an announcement shall not be grounds for redress. This changes RRS 62.1(a).

A3.4 **COURSE 1** – If numeral pennant “1” is displayed, the course will be clockwise around Conanicut Island:

- Special Mark “E”, if used (see SI A4.3)
- RG “NR” Bell 650 yards SW of Beavertail Point to starboard
- The center span of the Jamestown Verrazano Bridge
- C “5” 1,250 yards NW of Conanicut Point to starboard
- R “2” Fl R 4 Sec Bell 900 yards NE of Conanicut Point to starboard
- The center span of the Newport Jamestown Bridge
- Pass to the west of R “12” off Rose Island
- Finish off Fort Adams between a staff displaying a blue flag on a race committee boat and the finishing mark, which will be a PINK tetrahedron buoy. The finishing line will be located approximately 0.4 NM north of the Fl R 6 sec Horn “2” on the northern point of Fort Adams.

A3.5 **COURSE 2** – If numeral pennant “2” is displayed, the course will be counter-clockwise around Conanicut Island:

- Special Mark “E”, if used (see SI A4.3)
- Pass to the west of R “12” off Rose Island
- The center span of the Newport Jamestown Bridge
- R “2” Fl R 4 Sec Bell 900 yards NE of Conanicut Point to port
- C “5” 1,250 yards NW of Conanicut Point to port
- The center span of the Jamestown Verrazano Bridge
- RG “NR” Bell 650 yards SW of Beavertail Point to port
- Finish off Fort Adams between a staff displaying a blue flag on a race committee boat and the finishing mark, which will be a PINK tetrahedron buoy. The finishing line will be located approximately 0.4 NM north of the Fl R 6 sec Horn “2” on the northern point of Fort Adams.

A3.6 **COURSE 3** - If numeral pennant “3” is displayed, the course will be designated using buoys as described in SI Addendum A4. The race committee will list the marks in the order to be rounded and the required side to leave each mark. The course will be:

- Start
- Round the marks in the designated order leaving each mark to the designated side
- Finish between a staff displaying the blue flag on the race committee boat and the nearby finishing mark. Note that the intended finishing line will be set at the starting location of the race committee signal boat.

A3.7 In fog at the finish, the race committee boat may ring a bell rapidly, for approximately 5 seconds, at intervals.

A3.8 The same race committee boat may or may not start and finish each race.

A4 ADDITIONAL MARKS

A4.1 All buoys listed on the *2015-2017 South Bay Race Chart* provided at registration may be used in Course 3. In addition, the marks listed in SI Addendum A4.3 and A4.4 below are additional rounding marks that might be used.

A4.2 The *South Bay Race Chart* is to be used for informational purposes only and should not be used for navigation.

A4.3 SPECIAL MARKS

Special Mark “E”

- a) The race committee may add a new first mark “E” to any course described in SI Addendum A3.
- b) If special mark “E” is used, the race committee will display flag “E” over a GREEN flag (round special mark “E” to STARBOARD) or over a RED flag (round special mark “E” to PORT).
- c) In Course 3, the race committee will also list “E” as the first mark on the course board as described in SI A3.6.
- d) The magnetic bearing and distance (in nautical miles to the nearest tenth) to special mark “E” will be posted on a whiteboard on the race committee signal boat.



Special Mark “L”

- a) The race committee may set special mark “L” approximately 0.1 NM to windward of the start line.
- b) If special mark “L” is used, it will be listed as a mark as described in SI Addendum A3.6.

A4.4 GOVERNMENT MARKS & ISLANDS

See charts 13205, 13218, 13223, 13226 and 13224 for more detail.

	<u>Description</u>	<u>Approx. location</u>
A	Gould Island	41° 32.00' N; 071° 20.67' W (center of island)
B	Hope I (east of Quonset) including R “2” at the southwest end and G C “1” at the northeast end	
C	Conanicut Island	
D	RW “NB” Mo(A) WHIS	41° 23.00' N; 071° 23.36' W
G	R “2” Fl R 4s WHIS south of Point Judith	41° 18.46' N; 071° 28.35' W
H	RW “SR” Mo(A) WHIS	41° 25.76' N; 071° 13.38' W
1BI	G “1 BI” Fl G 4s BELL north of Block I	41° 15.49' N; 071° 34.55' W
M	Block Island including:	
	R “4” Fl R 6s WHIS off Southwest Pt	41° 08.73' N; 071° 37.35' W
	Black Rock Pt. Buoy 2	41° 08.42' N; 071° 35.74' W
U	Buzzards Light Tower Fl 2.5s 67ft 17M Horn	41° 23.82' N; 071° 02.08' W
PR	Prudence Island including R “8” northwest of Patience Island and RG N at the northern end	
SP	RG “SP” Fl (2+1) R 6s BELL	41° 36.92' N; 071° 17.59' W
G3	G “3” Fl G 4s (approx. 0.5 NM sw of Popasquash Neck)	41° 38.53' N; 071° 18.46' W
MH	RGR “MH” Fl (2 +1) R 6s GONG in Mt. Hope Bay	41° 39.54' N; 071° 14.04' W
BH	RGR N "Middle Ground Buoy" approx. 0.8 NM n of Hog I	41° 39.68' N; 071° 16.87' W
HI	G “3” Fl G 4s BELL approx. 0.4 NM south southeast of Hog I	41° 37.79' N; 071° 16.29' W

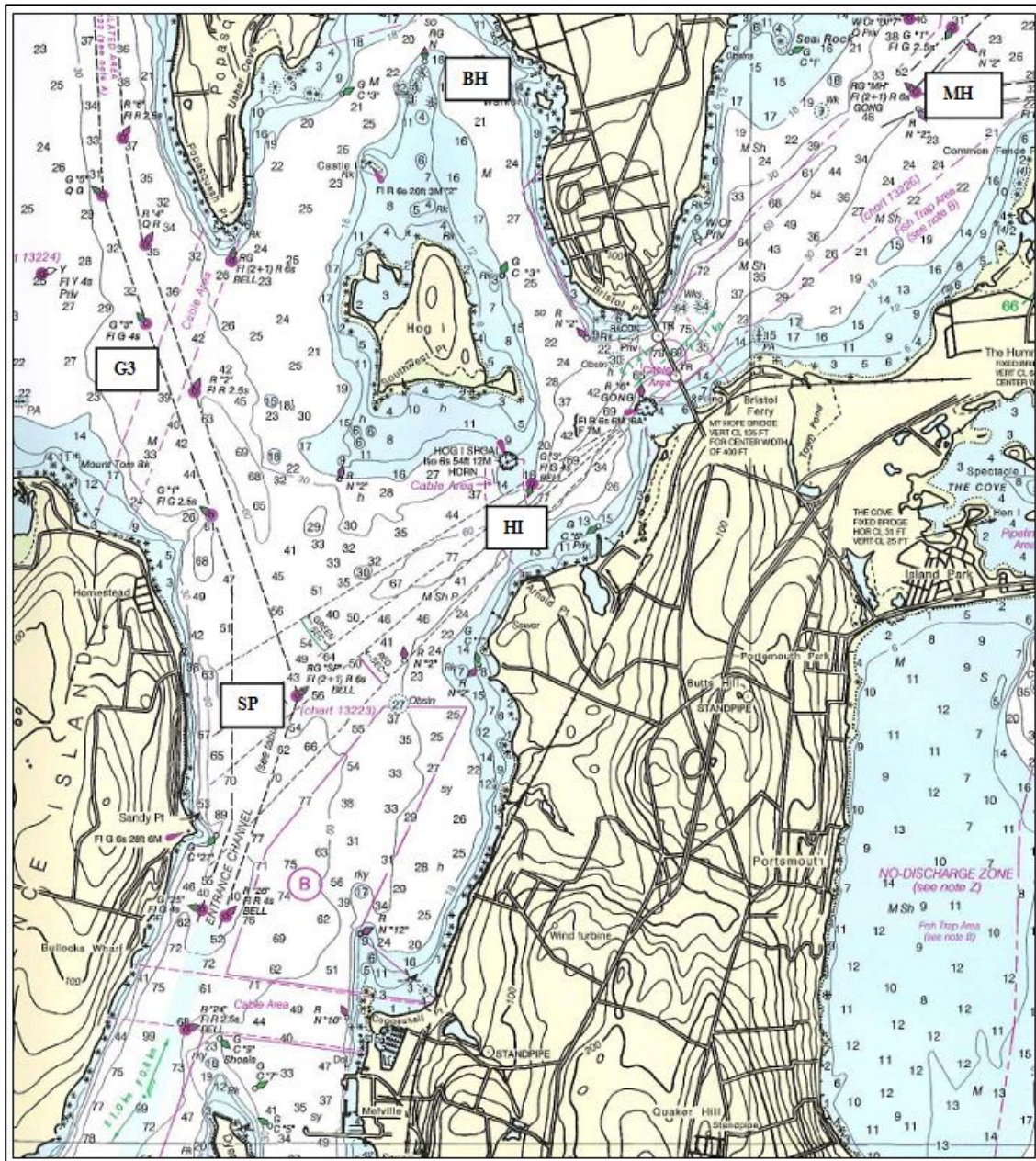

Marks near Prudence Island, Bristol and Mt. Hope Bay

SAILING INSTRUCTIONS

Addendum B – DROP MARK RACES

Saturday-Sunday, June 10-11

B1 COURSES FOR DROP MARK RACES

B1.1 The race committee signal boat will signal the course by displaying a letter flag and, for course “W”, a numeral pennant as follows:

- W2 Start – 1 – 1A – Finish (downwind)
- W3 Start – 1 – 1A – Gate (3A/3B) – Finish (upwind)
- W4 Start – 1 – 1A – Gate (3A/3B) – 1 – 1A – Finish (downwind)
- W5 Start – 1 – 1A – Gate (3A/3B) – 1 – 1A – Gate (3A/3B) – Finish (upwind)
- W6 Start – 1 – 1A – Gate (3A/3B) – 1 – 1A – Gate (3A/3B) – 1 – 1A – Finish (upwind)
- O Start – 1 – 1A – 2 – 3A – 1 – 1A – 3A – Finish (downwind)
- K Start – 1 – 1A – 2 – 3A – 1 – 1A – Finish (downwind)

B1.2 Course Diagrams

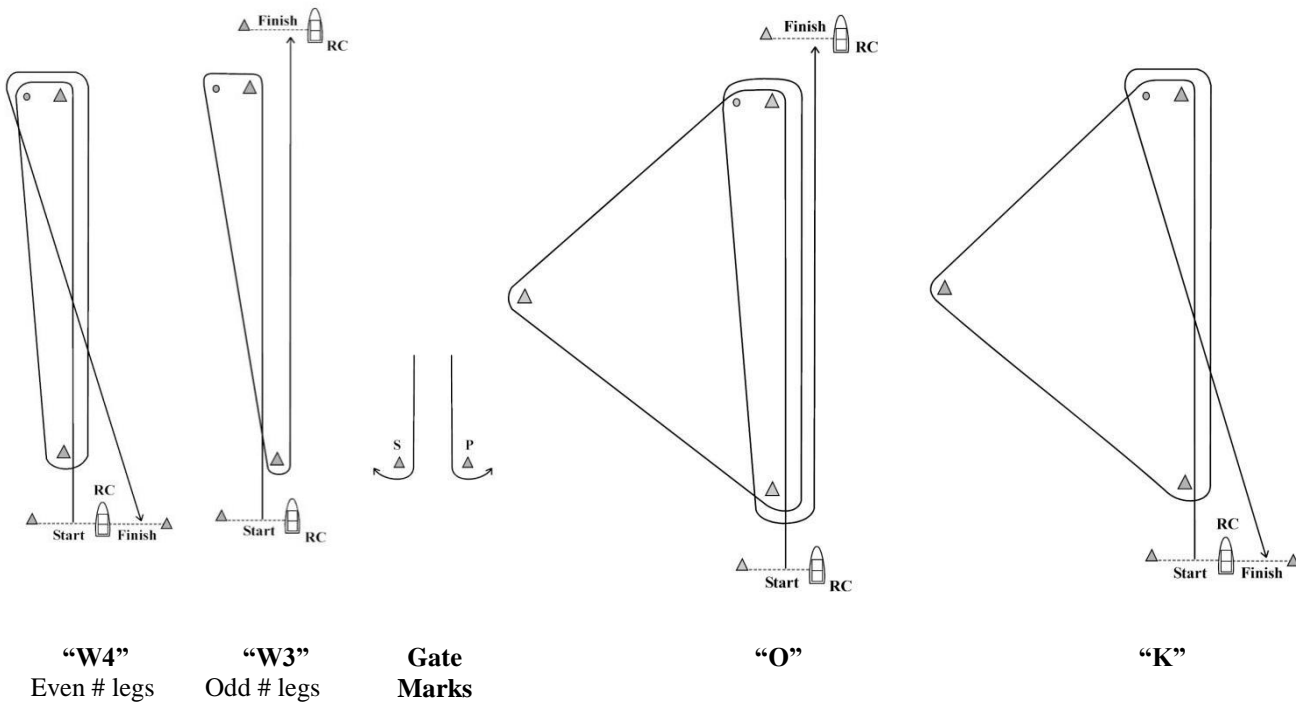

B1.2 **Course “W”** is a Windward/Leeward course with a windward offset mark. A numeral pennant indicating the number of **LEGS** to be raced will be flown beneath Flag “W”. The distance between the windward mark and the offset mark shall not count as a leg for the purposes of indicating the number of legs.

B1.3 **Course “O”** is a Triangle/Windward/Leeward/Windward course.

B1.4 **Course “K”** is a Triangle/Windward/Leeward course.

B1.5 The leeward mark for Courses “W”, “O”, and “K” will be an inflatable mark(s) set approximately 0.10 NM to windward of the starting line. A gate mark may be used for Course “W”.

B1.6 The course designation, distance and bearing to the windward mark will be signaled using flags displayed on poles or a whiteboard. The course designation will be flown forward, followed by the three numeral pennants designating the magnetic bearing to the first mark, followed by the two numeral pennants designating distance (nautical miles and tenths) to the first mark.

Example shown:

Course W4 with a long windward mark (see SI B1.9); windward mark 195° at 3.6 nm

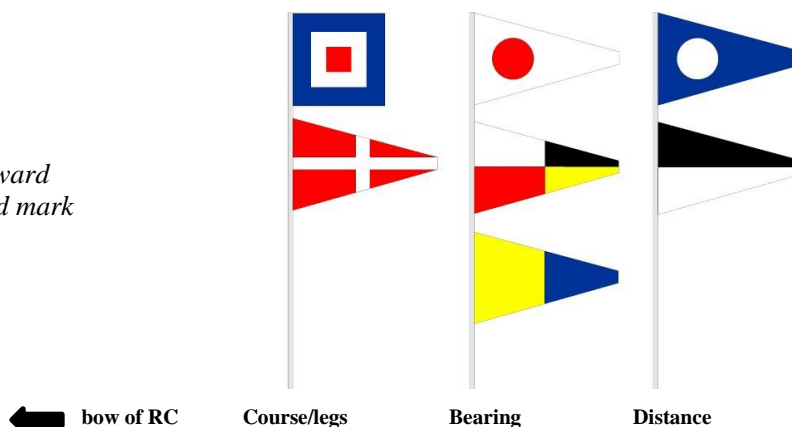

B1.7 Marks, including the windward offset mark, shall be rounded in order and always left to port, except that a gate, when used, shall be rounded as described in RRS 28.1(c).

B1.8 There will be a windward offset mark adjacent to the windward mark for all drop mark courses except as noted in SI Addendum B1.9(c).

B1.9 Long Windward Mark:

- a) For course “W” with an even number of legs, the race committee may set a long windward mark and a short windward mark.
- b) The distance displayed will be to the SHORT windward mark. The long windward mark will be on the same bearing at a distance of 1.0 NM beyond the short windward mark.
- c) There will be no offset mark at the long windward mark.
- d) If flag “D” is displayed below the course signals (see diagram on previous page), that class will use the LONG windward mark for each weather leg in that race. If flag “D” is NOT displayed below the course signals, that class will use the SHORT windward mark for each weather leg in that race.



This changes the diagrams in SI Addendum B1.1, as well as SI Addendum B1.2, B1.7, B1.8 and B2.2.

B1.10 Special Finish Mark “F”

If flag “F” is displayed on a separate pole, the finishing line for that class will be between a staff displaying a blue flag on a race committee boat and an ORANGE finishing mark approximately 0.4 NM north of the Fl R 6 sec Horn “2” on the northern point of Fort Adams. In the absence of the race committee boat and/or finishing mark, the finishing line will be on a bearing of 120° from G “3” Gong southeast of Rose Island. This changes the diagrams in SI Addendum B1.1, as well as SI Addendum D1.2, D1.7 and D2.1.

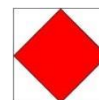

B2 MARKS FOR DROP MARK COURSES

B2.1 Marks will be inflatable buoys as follows:

<u>Circle</u>	<u>Original marks</u>	<u>Starting</u>	<u>Finishing</u>	<u>Change marks</u>
WHITE	Orange	Yellow	Green	Orange
BLUE	Yellow	Orange	Pink	Yellow
RED	Yellow	Orange	Green	Orange
GREEN	Yellow	Orange	Pink	Orange

B2.2 Offset marks will be small round orange buoys.

B3 COURSE CHANGE

- B3.1 In addition to the requirements in RRS 33, the race committee will attempt to announce any course change on their respective circle VHF channel. Failure to make such an announcement shall not be grounds for redress. This changes RRS 62.1(a).
- B3.2 The new mark will be a different color (orange or yellow) from the original mark as described in SI Addendum B2.1. For a subsequent change, the new mark will be the same as the original mark.

B4 THE FINISH

- B4.1 The finishing line will be between a staff displaying a blue flag on a race committee boat and the finishing mark.
- a) For Course “W”, with an odd number of legs, and Course “O”, the finish line will be located approximately 0.1 NM to windward of the windward mark.
 - b) For Course “W”, with an even number of legs, and Course “K”, the finish line will be located approximately 0.1 NM to leeward of the leeward mark and the finishing mark will be on the opposite side of the race committee signal boat from the starting mark. See diagrams in SI Addendum B1.1.
- B4.2 If a subsequent race is to be sailed, the finish line race committee boat intends to fly Pennant “Second Substitute” with the Blue “On-Station” signal at the finish. If a Class Flag is displayed below Pennant “Second Substitute” the subsequent race is for that class(es) only. In addition, the race committee will attempt to announce a subsequent race on their respective circle VHF channel.
- B4.3 In fog at the finish, the race committee boat may ring a bell rapidly, for approximately 5 seconds, at intervals. The same race committee boat may or may not start and finish each race.

SAILING INSTRUCTIONS

Addendum C – NYYC PRIMARY RACE AREAS

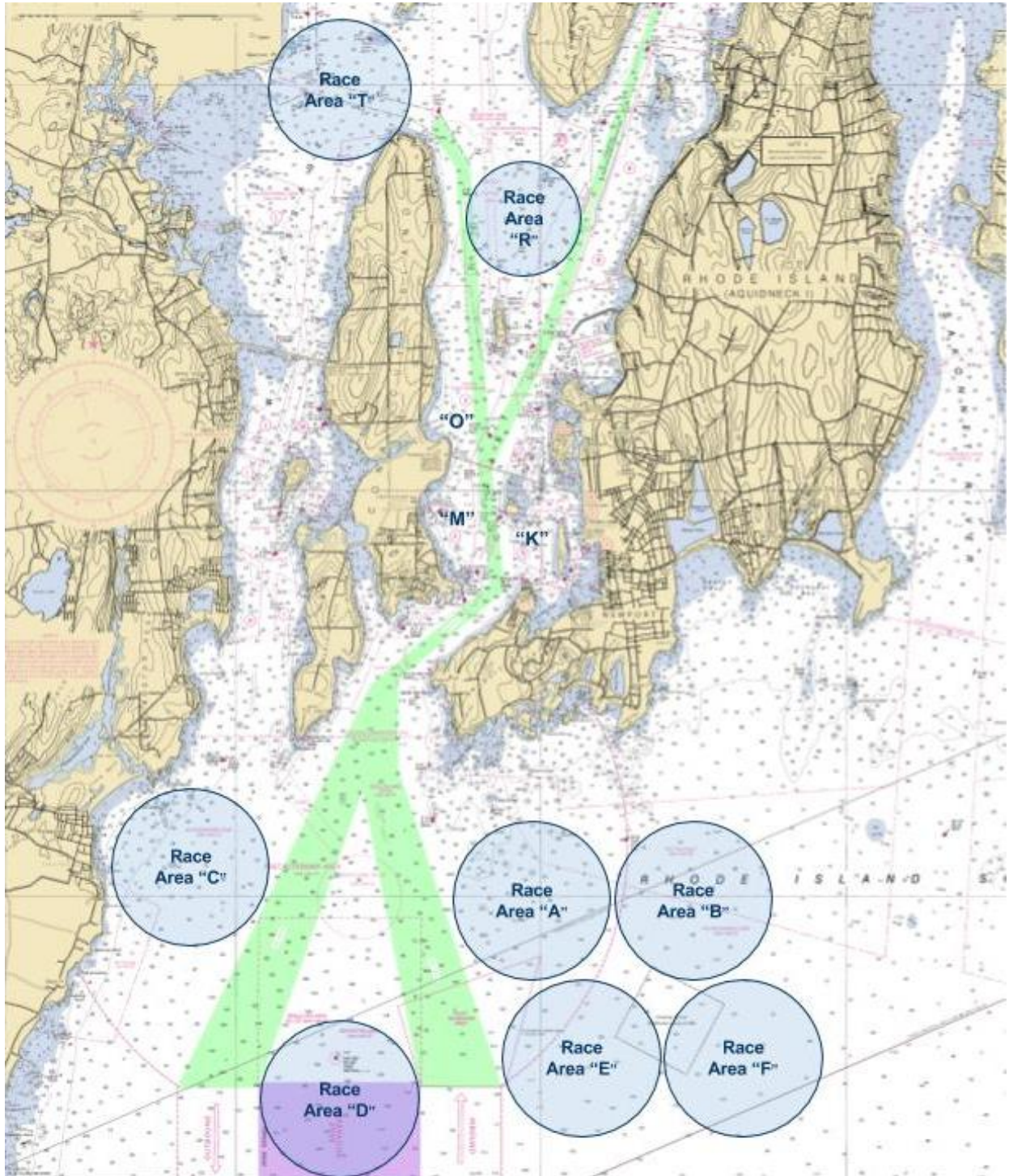

SAILING INSTRUCTIONS

Addendum D – M32 Special Instructions

Saturday-Sunday, June 11-12

In accordance with SI 1.12, this appendix to the Sailing Instructions pertains to the M32 Class in the 163rd NYYC Annual Regatta presented by Rolex. Where there is a conflict between this appendix and the Notice of Race or Sailing Instructions, this appendix shall prevail. This changes RRS 63.7.

The M32 Class will sail courses as described in SI Addendum B – Drop Mark Races or as described in Addendum D below. Class rules are posted at <http://m32series.com/officialnoticeboard/>.

D1 CHANGES TO THE SAILING INSTRUCTIONS

D1.1 CHANGE SI 1.2 (a) to read:

- 1.5 a) All crew members shall wear approved non-inflatable PFDs at all times while racing and carry helmets on board at all times.

D1.2 ADD SI 1.14

- 1.15 RRS 31, Touching a Mark, is changed to read: While racing, a boat shall not touch a starting mark before starting or a finishing mark after finishing. Boats are permitted to touch a rounding mark.

D1.3 ADD SI 1.15

- 1.16 Spinnakers may be set on any leg of the race course. However:
- a) The spinnaker must be sheeted outside the sidestays; and
 - b) when sailing with a spinnaker on an upwind leg, no crew members may be positioned out on the rack.

D1.4 DELETE SI 4.4 and SI 4.5 and REPLACE with SI 4.4 to read:

- 4.5 Each yacht shall fly the Rolex flag provided at registration from her starboard shroud. Each yacht shall display the Rolex stickers provided at registration on the inside of each bow. No class flag is required to be flown.

D1.5 CHANGE SI 9 and REPLACE with:

9 THE START

The starting sequence will be as follows:

4:00	Warning Signal	Class flag ↑	Sound signal
3:00	Preparatory Signal		Sound signal
2:00			Sound signal
1:00			Sound signal
0:00	Start	Class flag ↓	Sound signal

D1.6 CHANGE SI 10 to read:

10 INDIVIDUAL RECALL

10.1 The Race Committee will hail each premature starter over the circle VHF channel.

10.2 Boats that are OCS shall choose to:

- a) return to start correctly in compliance with RRS 29.1; or
- b) immediately slow until they are clear astern of all boats that have started correctly. However, an OCS boat need not sail clear astern of a boat that has capsized. This changes RRS 29.1.

D1.7 CHANGE SI 13.4 to read:

- 13.4 Rule 44.1 is changed so that the first three sentences, including the Two-Turns Penalty, is replaced by “A boat may take a penalty by sailing two hull lengths behind the boat(s) they have fouled when she may have broken one or more rules of Part 2 in an incident while racing.”

D2 COURSE & MARKS

D2.1 The course is:	<u>Mark</u>	<u>Color/shape</u>	<u>Required Side</u>
	Start	Yellow	
	Mark 1 Reach	Yellow conical	leave to port
	Leeward Gate	Green conical	gate
	Windward Gate	Blue conical	gate
	Leeward Gate	Green conical	gate
	Mark 1 Reach	Yellow conical	leave to starboard
	Finish	Yellow	

D2.2 The course diagram below shows approximate angles and distances. The angles and distances may vary depending on the wind strength or other factors.

D2.3 The race committee will not signal any course flag.

